

# Assembly Instructions

## Tools required for assembly

- 1/2 inch open or boxed end wrench
- Pair of pliers
- 5/16 inch open or boxed end wrench

1. Arrange carton contents as shown in figure 1 on page two, and hardware as shown in figure 1 on page 2.
2. Insert the short end of the two handle braces through the slots and over the two pins in the end plates as shown in figure 2 below.
3. Attach the two upper handles to the handle braces with two 5/16-18 x 2 1/4 inch bolts as shown in figure 4. Hand tighten the nuts.
4. Assemble the upper handles at the top with a 5/16-18 x 1 3/4 inch bolt and nut. Hand tighten.
5. Assemble the #12 x 1 inch hex washer head screw that goes into the handle panel and into the spacer. Place the handle panel over the handle so that the screw is lined up with the notch between the two upper handles as shown in figure 5.
6. Tighten all four handle bolts and nuts as shown in figures 3 and 4.

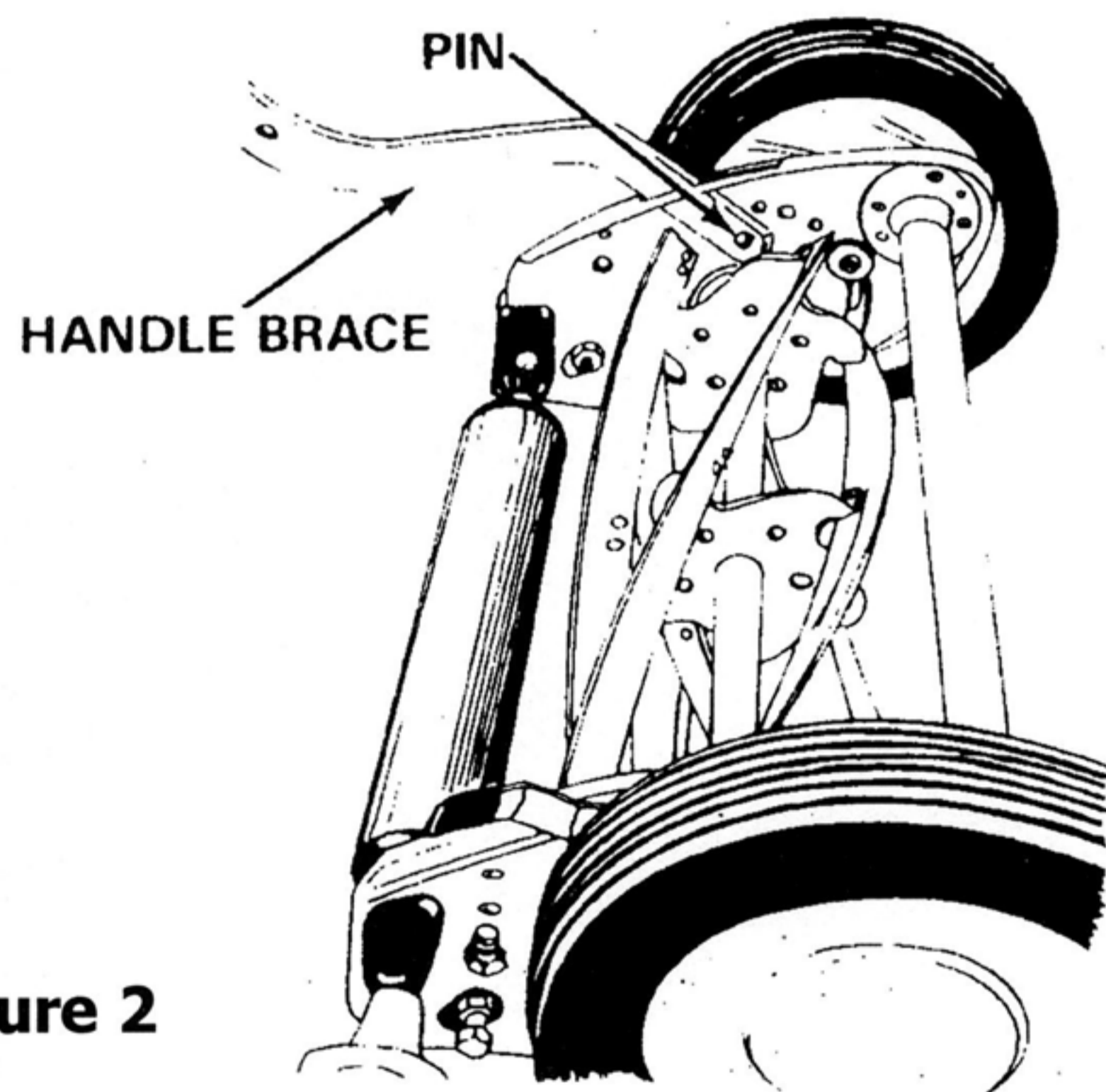

Figure 2

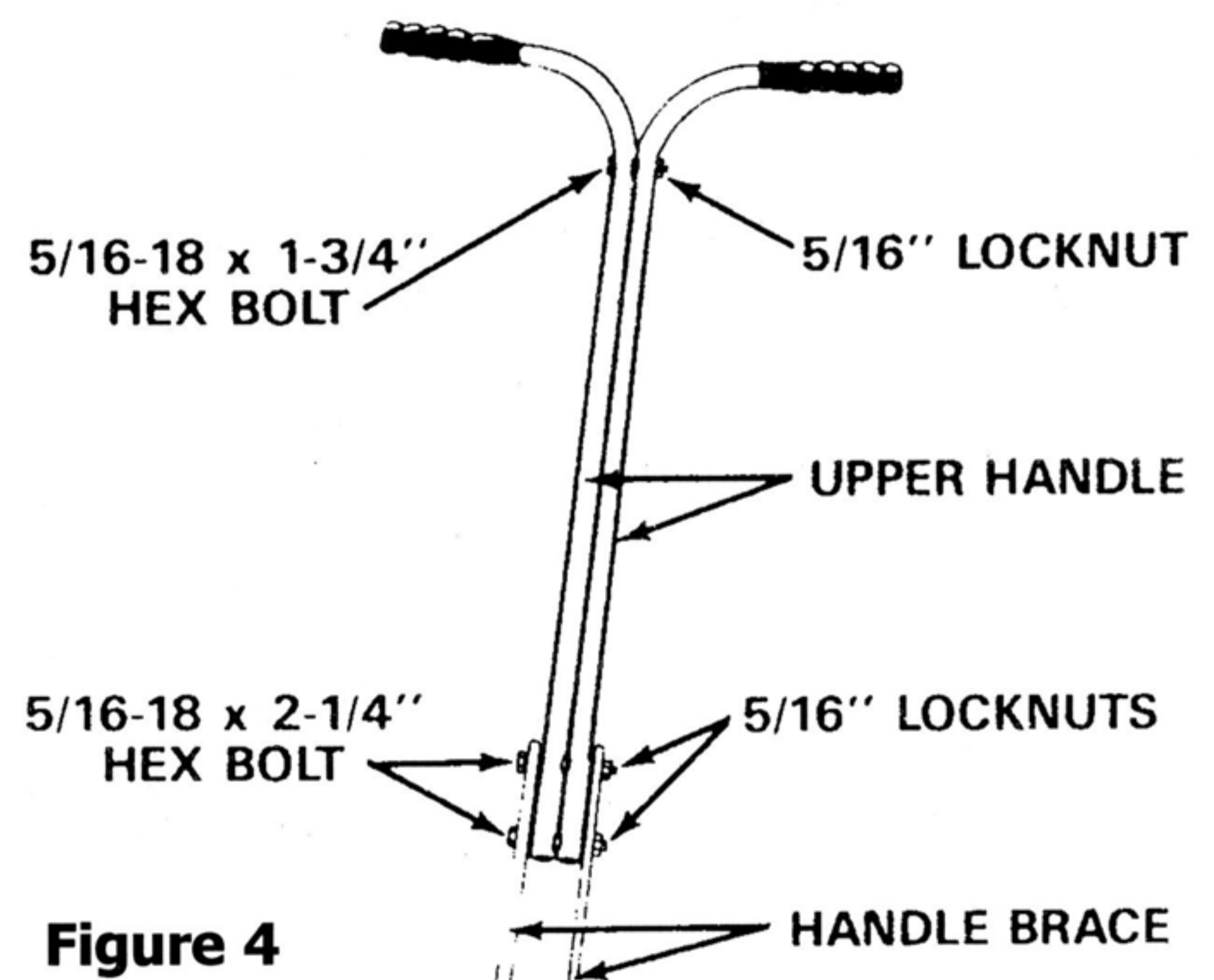

Figure 4

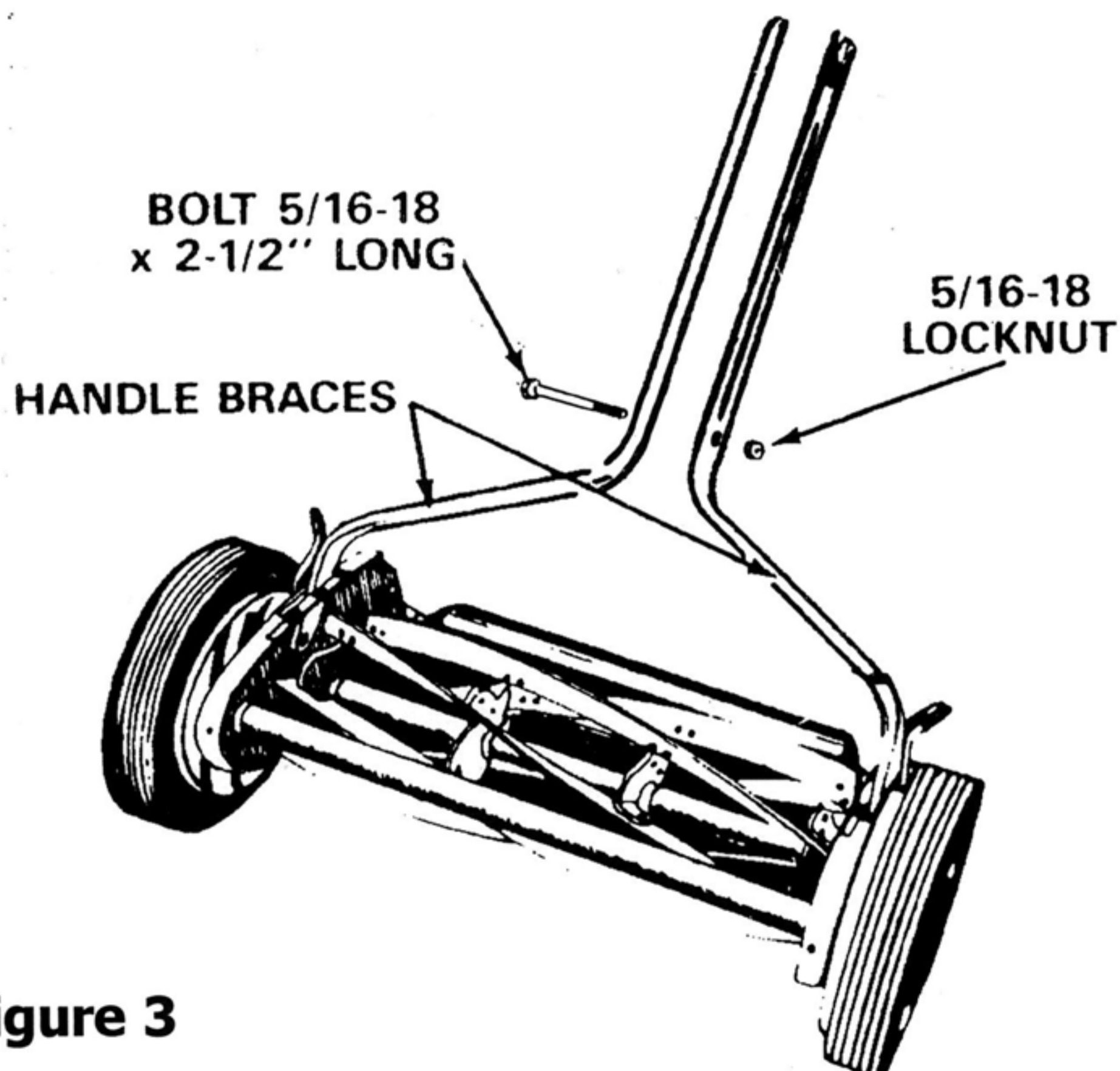

Figure 3

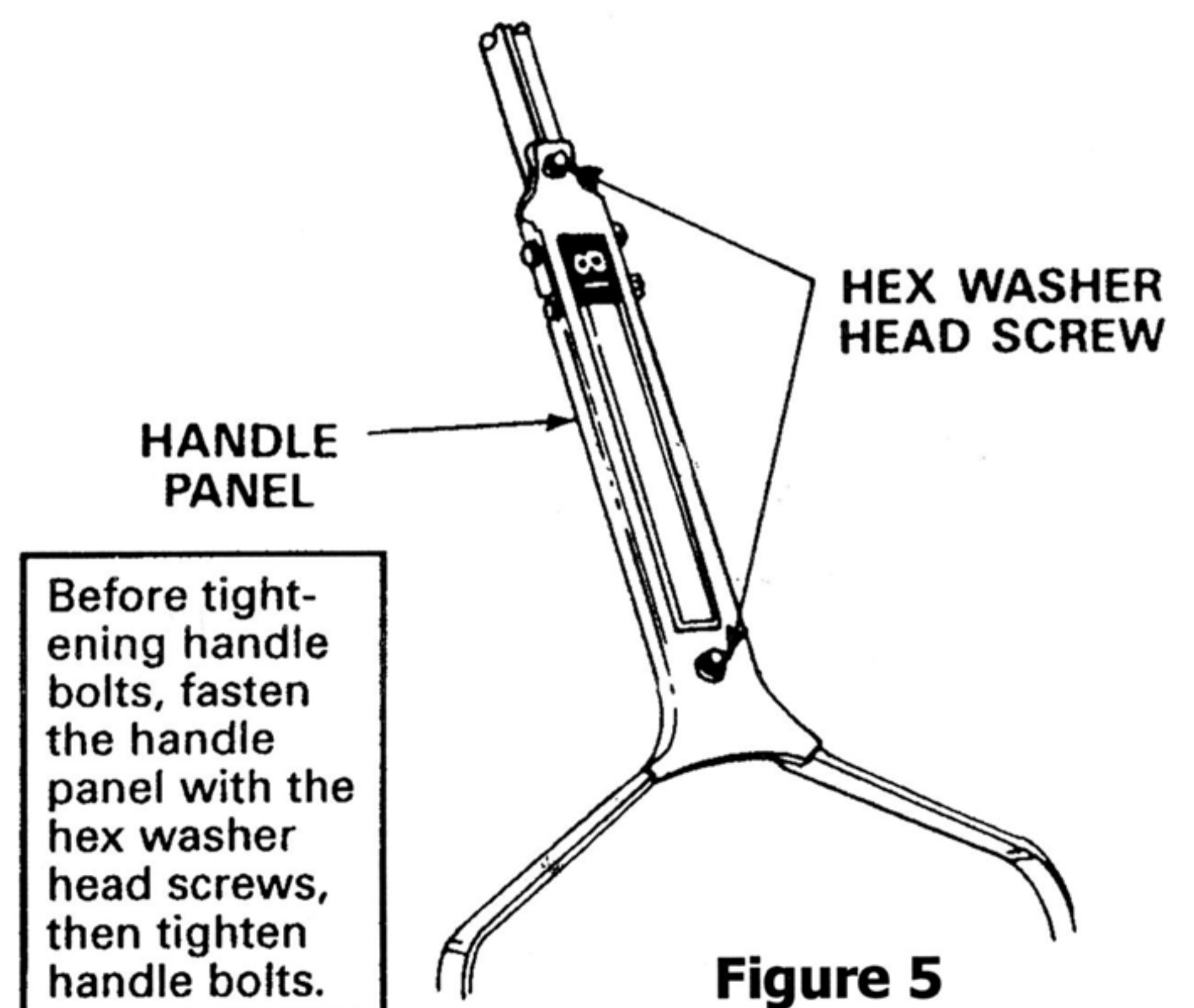

Figure 5